

N.b. ROD-EYE ORIENTATION NOT GUARANTIED.

ELECTRICAL OPTIONS/ SPECIFICATIONS

OUTPUT SUPPLY
 0.5 TO 4.5V RATIO METRIC 5V
 SUPPLY CURRENT 12mA TYP. 20mA MAX.

CABLE LENGTH, OPTION 'Lxx', ORDERED IN cm, 50cm
 STANDARD OR AS REQUIRED, 1500cm MAX.
 3-CORE SCREENED: 0.2mm², Ø4mm PUR JACKET

CABLE/CONNECTOR CONNECTIONS*;
 3 CORE CONNECTOR

RED :1 +Ve
 BLACK :3 0V
 WHITE :2 OUTPUT
 SCREEN :4 BODY

*CONNECTORS; MAXIMUM CONDUCTOR CROSS SECTION 0.75mm²
 RANGE OF DISPLACEMENT FROM 10mm TO 350mm,
 IN INCREMENTS OF 1mm.

BODY MATERIAL: STAINLESS STEEL.

FURTHER OPTIONS:
 PUSH-ROD FREE (CODE 'V')

NOTE:- READ INSTALLATION SHEET E117-19
 FOR FULL INSTRUCTIONS FOR USE.

ATEX APPROVED TO	
II 1GD	
EEx ia IIC T4 (Ta= -40° to +80°C)	
Ex iaD 20 T135°C (Ta= -40° to +80°C)	
Ui 11.4V, Ii 0.2A, Pi 0.51W	
APPROVED FOR USE IN CONJUNCTION WITH A GALVANICALLY ISOLATED BARRIER.	

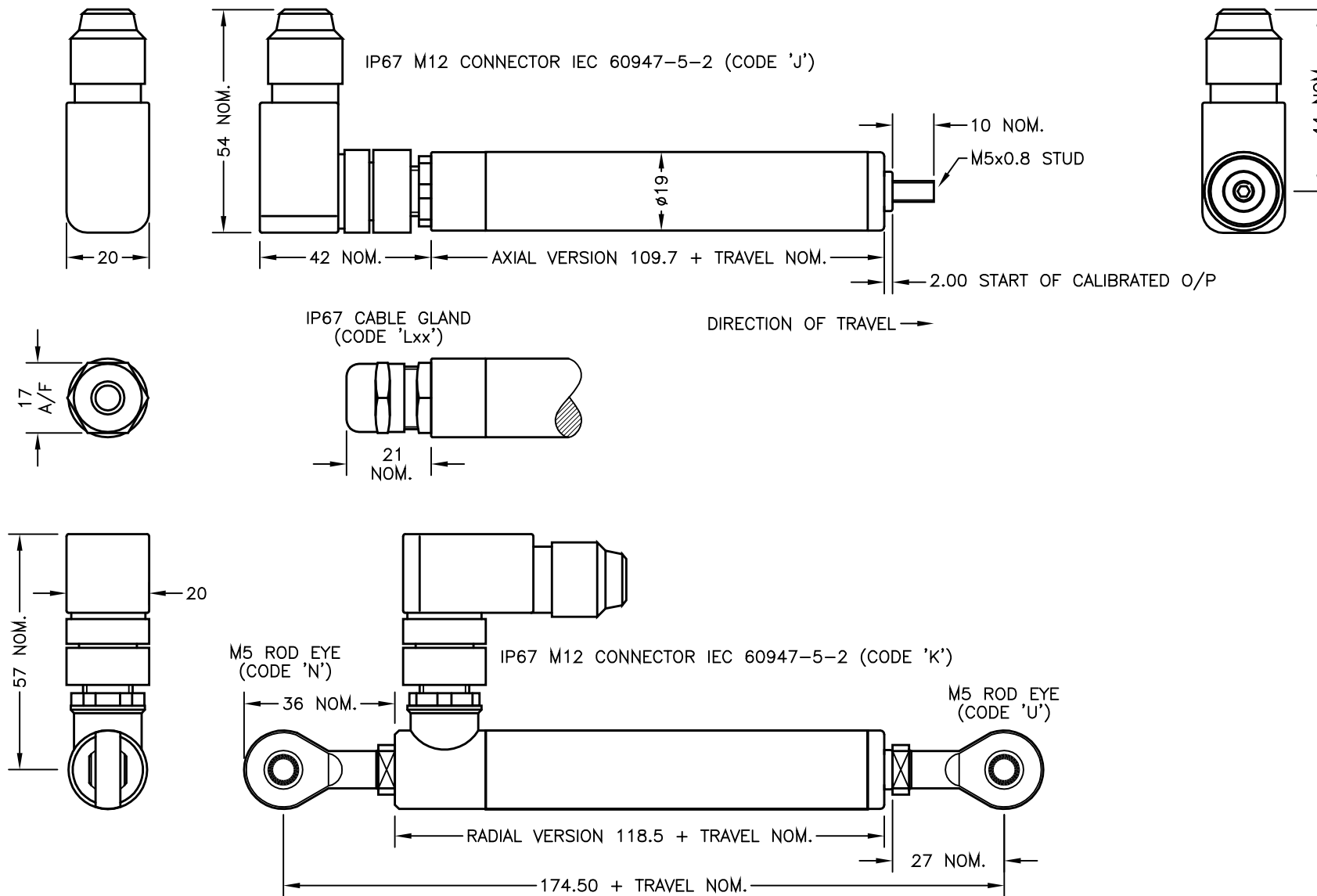

A	FIRST ISSUE	RDS
B	Ii 0.2A WAS 0.46A - RAN266	PDM
C	ADDITIONAL DIMS/VIEWS ADDED.	PDM

THE PUSH-ROD RETRACTS AND EXTENDS 2mm NOM. AT EITHER END OF CALIBRATED TRAVEL.
 'V' CODED PUSH-ROD WILL DEPART SENSOR BODY.

DRAWINGS NOT TO BE CHANGED WITHOUT REFERENCE TO THE CHANGE PROCEDURE.
 CHANGES TO PARTS USED IN INTRINSICALLY SAFE PRODUCT MUST BE APPROVED
 BY THE AUTHORISED PERSON
 THIS IS AN UNCONTROLLED PRINT AND WILL NOT BE UPDATED.



A	09/12/09		CHECKED BY	X	±0.4
B	21/04/10		RDS	X.X	±0.2
C	06/07/11			X.XX	±0.1
DESCRIPTION					DIMS mm
E117 INTRINSICALLY SAFE SLIM-LINE LINEAR POSITION SENSOR					
SCALE 1:3mm		DRAWING NUMBER		E117-11	REV C
					SHEET 1 OF 1