

**Dimensions**

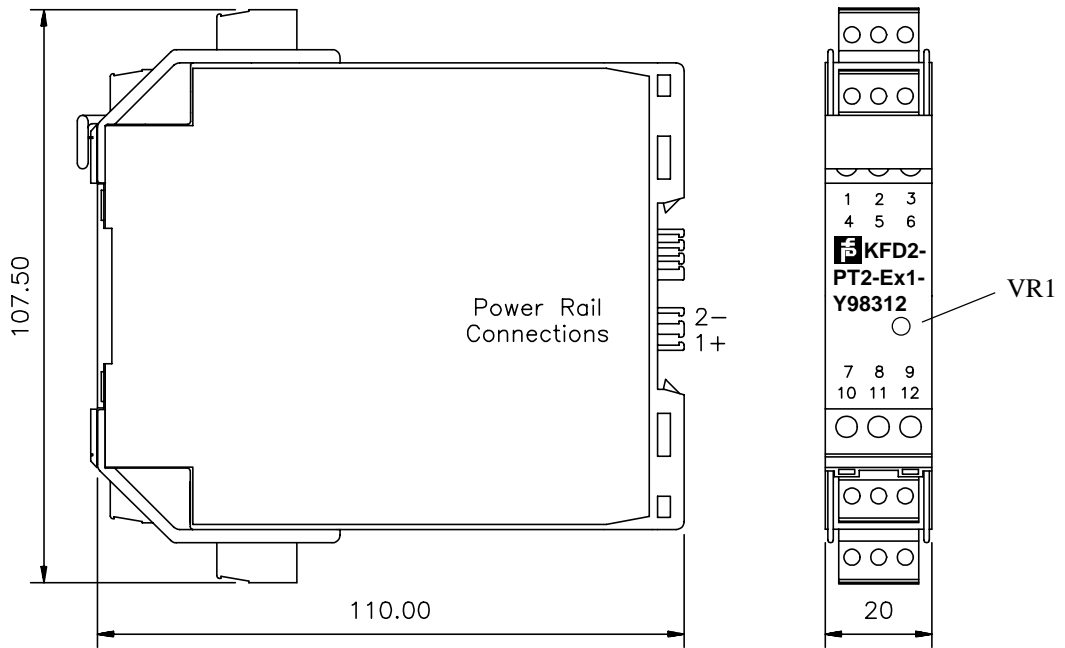

Barriers may be mounted either on 35mm transverse symmetrical rail (DIN 46277) or fixed through extended latches hole centres are 90mm apart, diameter 4.2mm. Power rail type PR02 (which lies in standard DIN rail) for power rail mounting.

**Schematic Circuit Diagram**

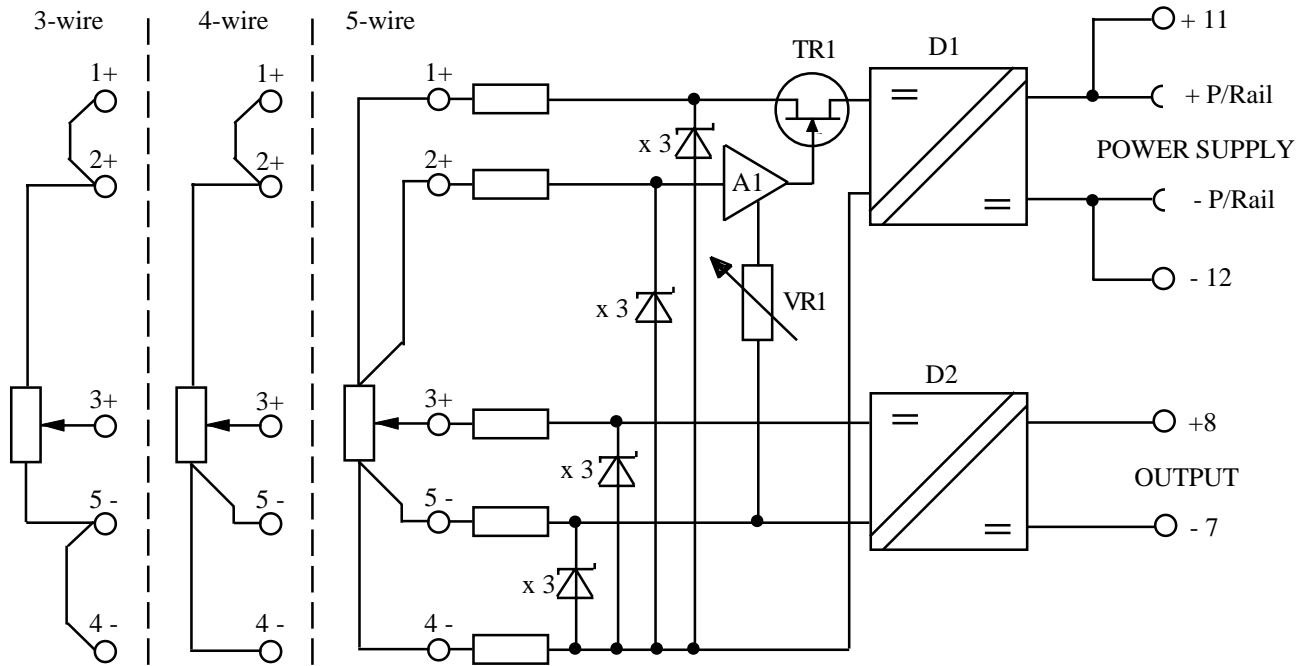

THIS DRAWING MUST NOT BE CHANGED WITHOUT THE PRIOR PERMISSION OF THE CHIEF ENGINEER.

	15.8.01	Date	All dimensions in mm unless otherwise stated.	Material	Scale
	GB-TC	Drawn			
	GB-RAS	Checked	Title Data sheet for Potentiometer Amplifier type KFD2-PT2-Ex1-*Y...		
	GB-KC	Approved			
	E	Issue			
	See change note 300-5040A.	Change	Drawing List No. DL1040		
			Parts List No. 252-1300		
			PEPPERL + FUCHS Oldham, Lancs.	Drawing No. 259-0694E	
				Sheet 1 of 5	

**Description**

The KFD2-PT2-Ex1 is used to supply power to a potentiometer located in a potentially explosive atmosphere, and to transfer the voltage on the wiper, which may be used for position indication or control purposes.

The power supply and voltage input circuits are certified intrinsically safe [EE ia] IIC. The hazardous area connections are transformer isolated from the safe area connections so a high integrity intrinsically safe earth is not required. The unit may also be used with intrinsically safe circuits which have difficulty in meeting the 500V insulation test without the need for a special equalisation conductor back to an intrinsically safe earth.

A power supply of 20-35V d.c. is connected to the power rail terminals to power d.c. to d.c. converter D1. The output from D1 is regulated by A1 and TR1 to provide a power supply for the potentiometer resistance. The KFD2-PT2-Ex1 can be used with a 3, 4 or 5-wire connection to the potentiometer.

5-wire connection should be used for greatest accuracy, terminal 2 senses the positive side of the potentiometer and terminal 3 senses the negative side to compensate for lead resistance of upto 5% per lead.

4-wire connection uses terminal 2 linked to terminal 1 and the positive lead resistance is not compensated for. However VR1 on the front plate can be adjusted to increase the voltage at terminals 1 and 2 to give full scale output for lead resistance upto 5% of the potentiometer value.

3-wire connection is similar to 4-wire connection except that terminals 4 and 5 are also linked and the negative lead resistance is not compensated for. This produces an offset corresponding to the lead resistance at the bottom of the potentiometer. The lead resistance should be a small enough proportion of the potentiometer resistance to give the required accuracy. (Full scale output can still be adjusted as for 4-wire connection).

The Y98312 and Y112844 versions are designed to operate with the Electronics Interface type EX01 built in a Positek Inductive Position Sensor. That device is similar in its application to a potentiometer (it has 3 wires and the 3rd carries a voltage proportional to position) but the supply leads need from 4.0 to 5.5V at 12mA nominal, 15mA maximum. The KFD2-PT2-Ex1... supplies about 4.8V to the Positek device (as normal) and with 15mA flowing there can be up to 12 ohms in each supply lead. The Y98312 and Y112844 versions are designed to give 0.5 to 9.5V and 4 to 20mA respectively with the corresponding Positek sensor over the calibrated range of the sensor.

The KFD2-PT2-Ex1-*Y*... is available with a current or voltage output signal (terminals 7 and 8) as listed below:

- KFD2-PT2-Ex1-Y98312      0-10V Output
- KFD2-PT2-Ex1-1-Y107265    0-5V Output
- KFD2-PT2-Ex1-2-Y107266    2-10V Output
- KFD2-PT2-Ex1-3-Y107267    1-5V Output
- KFD2-PT2-Ex1-4-Y107268    0-20mA Output
- KFD2-PT2-Ex1-5-Y107269    4-20mA Output
- KFD2-PT2-Ex1-6-Y112844    0-24mA (20mA output at 4V nominal input)

THIS DRAWING MUST NOT BE CHANGED WITHOUT THE PRIOR PERMISSION OF THE CHIEF ENGINEER.

	15.8.01	Date	All dimensions in mm unless otherwise stated.	Material	Scale
	GB-TC	Drawn			
	GB-RAS	Checked	Title Data sheet for Potentiometer Amplifier type KFD2-PT2-Ex1- <i>Y</i> ...		
	GB-KC	Approved			
	E	Issue			
	See change note 300-5040A.	Change	Drawing List No. DL1040		
			Parts List No. 252-1300		
			PEPPERL + FUCHS Oldham, Lancs.	Drawing No. 259-0694E	
				Sheet 2 of 5	

**Technical Data**

Power supply - Power rail terminals

Voltage 20 - 35V d.c.  
 Ripple within supply tolerance  
 Power consumption ca. 0.7W for voltage output  
 ca. 1.4W for current output

Input Circuit- terminals 1, 2, 3, 4 and 5

Transformer isolated,  
 Intrinsically Safe [EEx ia] IIC BAS00ATEX7171  
 U<sub>max out</sub> = 10.4V, I<sub>max out</sub> = 46mA

Potentiometer value 500ohms minimum  
 Voltage across potentiometer ca. 4.8 volts  
 Lead resistance compensation 4 and 5-wire 5% of potentiometer value  
 Lead resistance adjustment 3 and 4-wire 5% of potentiometer value  
 (adjusted out during commissioning by user)  
 Lead resistance for 15mA (all connections) 12ohms maximum  
 Input resistance terminal 3 17M ohms min.

Output Circuit terminals 7 and 8

Output options 0-10V, 0-5V, 0-20mA, 2-10V, 1-5V, 4-20mA  
 Output resistance (voltage output) ≤ 30 ohms  
 Load resistance (current output) 0 - 1k ohm

Transfer characteristics

Non - linearity ≤ ± 5mV for voltage outputs  
 ≤ ± 10µA for current outputs

Temperature drift ≤ 0.5mV/°C for voltage outputs  
 ≤ 1µA/°C for current outputs

Settling time to 1% of span ≤ 25ms  
 for 10 to 90% step change

Rise time from 10 to 90% of step change ≤ 8ms

Bandwidth d.c. to 100Hz (-3dB)

Isolation 2500V between safe area terminals and hazardous  
 area terminals. 50V between power rail terminals  
 and output terminals (7 and 8)

Electromagnetic Compatibility

THIS DRAWING MUST NOT BE CHANGED WITHOUT THE PRIOR PERMISSION OF THE CHIEF ENGINEER.

	15.8.01	Date	All dimensions in mm unless otherwise stated.	Material	Scale
	GB-TC	Drawn			
	GB-RAS	Checked	Title Data sheet for Potentiometer Amplifier type KFD2-PT2-Ex1-*-Y...		
	GB-KC	Approved			
	E	Issue			
	See change note 300-5040A.	Change			
			Drawing List No. DL1040		
			Parts List No. 252-1300		
			PEPPERL + FUCHS Oldham, Lancs.	Drawing No. 259-0694E	
				Sheet 3 of 5	

Details of test procedures used to determine the electromagnetic compatibility of P+F products are given in the P+F publication "Electromagnetic Compatibility Manual."

Emissions	Meet EN50081-2
Immunity	Meet EN50082-2
Ambient temperature range	-20 to 60°C working -40°C to +100°C storage
Protection class	IP 20
Housing material	Makrolon
Terminals	Phoenix Combicon plug-in terminal blocks, Self opening maximum conductor size 2.5mm <sup>2</sup>
Weight	ca. 120g

THIS DRAWING MUST NOT BE CHANGED WITHOUT THE PRIOR PERMISSION OF THE CHIEF ENGINEER.

	15.8.01	Date	All dimensions in mm unless otherwise stated.	Material	Scale
	GB-TC	Drawn			
	GB-RAS	Checked	Title Data sheet for Potentiometer Amplifier type KFD2-PT2-Ex1-*-Y...		
	GB-KC	Approved			
	E	Issue			
	See change note 300-5040A.	Change	Drawing List No. DL1040		
			Parts List No. 252-1300		
			PEPPERL + FUCHS Oldham, Lancs.	Drawing No. 259-0694E	
				Sheet 4 of 5	

ATEX Essential Safety Requirements

The following notes are included in order to comply with the Essential Safety Requirements of the ATEX Directive 94/9/EC.

1. This equipment must only be installed, operated and maintained by trained competent personnel.
2. This apparatus has been designed in accordance with EN50 014 and EN50 020, therefore the apparatus has been designed to meet the fault tolerant requirements of Associate Apparatus for Category 'ia'.
3. The installation and maintenance must be carried out in accordance with all appropriate international, national and local standard codes of practice and site regulations for intrinsically safe apparatus.
4. The installation and maintenance must be in accordance with the instructions contained in this data sheet.
5. Access to the circuitry must not be made during operation.
6. This product is an associated electrical apparatus and must not be installed in the hazardous area without the provision of further certified hazardous area protection.
7. This product must not be subjected to mechanical and thermal stresses in excess of those permitted in the certification documentation and the data sheet. If necessary the product must be protected by an enclosure to prevent mechanical damage.
8. This product must not be installed in a position where it may be attacked by aggressive substances.
9. This product must be protected from excessive dust by an enclosure etc.
10. This product cannot be repaired by the user and must be replaced by an equivalent certified product. Repairs should only be carried out by the manufacturer or approved repairer.
11. The test label serial number is created as follows :-

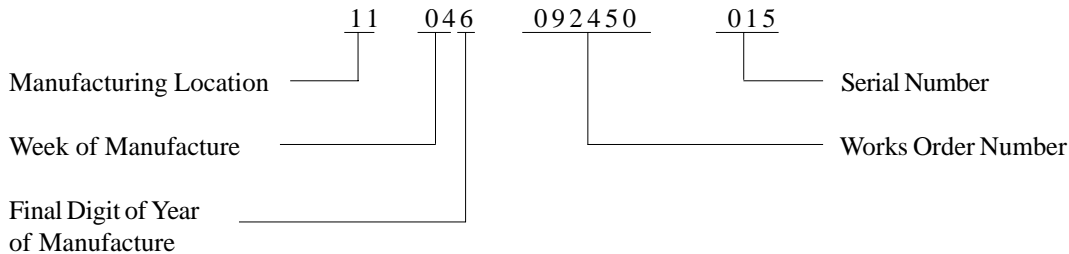

The decade in which the unit was manufactured can be determined by contacting Pepperl+Fuchs quoting the works order number.

12. This equipment is designed and manufactured to protect against other hazards as defined in paragraph 1.2.7 of Annex II of the ATEX Directive 94/9/EC.

THIS DRAWING MUST NOT BE CHANGED WITHOUT THE PRIOR PERMISSION OF THE CHIEF ENGINEER.

	15.8.01	Date	All dimensions in mm unless otherwise stated.	Material	Scale
	GB-TC	Drawn			
	GB-RAS	Checked	Title Data sheet for Potentiometer Amplifier type KFD2-PT2-Ex1-*-*Y...		
	GB-KC	Approved			
	E	Issue			
	See change note 300-5040A.	Change	Drawing List No. DL1040		
			Parts List No. 252-1300		
			PEPPERL + FUCHS Oldham, Lancs.	Drawing No. 259-0694E	
				Sheet 5 of 5	