

RIPS® P500 ROTARY SENSOR

High-resolution angle feedback for industrial and scientific applications

- Non-contacting inductive technology to eliminate wear
- Angle set to customer's requirement
- Compact, durable and reliable
- High accuracy and stability
- Sealing to IP65/IP67 as required



As a leading designer and manufacturer of linear, rotary, tilt and intrinsically safe position sensors, Positek® has the expertise to supply a sensor to suit a wide variety of applications.

Our P500 RIPS® (Rotary Inductive Position Sensor) is an affordable, durable, high-accuracy rotary sensor designed for industrial and scientific feedback applications.

The P500, like all Positek® sensors, is supplied with the output calibrated to the angle required by the customer, between 20 and 160 degrees and with full EMC protection built in. The sensor provides a linear output proportional with angle of rotation. There is a machined registration mark to identify the calibrated mid point.

It is particularly suitable for OEMs seeking good sensor performance for arduous applications such as industrial machinery where cost is important.

Overall performance, repeatability and stability are outstanding over a wide temperature range. The P500 has long service life and environmental resistance with a rugged stainless steel body and shaft, the flange and servo mounts are anodised aluminium. The flange or servo mounting options make the sensor easy to install, it also offers a range of mechanical and electrical options. Environmental sealing is to IP65 or IP67 depending on selected cable or connector options.

SPECIFICATION

DIMENSIONS

Body diameter	35 mm
Body Length (to seal face)	44 mm standard, 50 mm buffered
Shaft	15mm Ø 6mm
<i>For full mechanical details see drawing P500-11</i>	
Independent linearity	< ± 0.25% FSO up to 100° travel @ 20°C
Temperature coefficients	< ± 0.01%/°C Gain & < ± 0.01%FS/°C Offset
Frequency response	> 10 kHz (-3dB) > 300 Hz (-3dB) 2 wire 4 to 20 mA
Resolution	Infinite
Noise	< 0.02% FSO
Torque	<20 mNm Static
Environmental Temperature Limits	
Operating	-40 to +125°C standard -20 to +85°C buffered
Storage	-40 to +125°C
Sealing	IP65/IP67 depending on connector / cable option
EMC Performance	EN 61000-6-2, EN 61000-6-3
Vibration	IEC 68-2-6: 10g
Shock	IEC 68-2-29: 40 g
MTBF	350,000 hrs 40°C Gf
Drawing List	
P500-11	Sensor Outline
<i>Drawings, in AutoCAD® dwg or dxf format, available on request.</i>	

Do you need a position sensor made to order to suit a particular installation requirement or specification? We'll be happy to modify any of our designs to suit your needs - please contact us with your requirements.

RIPS[®] P500 ROTARY SENSOR

High-resolution angle feedback for industrial and scientific applications

How Positek's PIPS[®] technology eliminates wear for longer life

Positek's PIPS[®] technology (Positek Inductive Position Sensor) is a major advance in displacement sensor design. PIPS[®]-based displacement transducers have the simplicity of a potentiometer with the life of an LVDT/RVDT.

PIPS[®] technology combines the best in fundamental inductive principles with advanced micro-electronic integrated circuit technology. A PIPS[®] sensor, based on simple inductive coils using Positek's ASIC control technology, directly measures absolute position giving a DC analogue output signal. Because there is no contact between moving electrical components, reliability is high and wear is eliminated for an exceptionally long life.

PIPS[®] overcomes the drawbacks of LVDT technology – bulky coils, poor length-to-stroke ratio and the need for special magnetic materials. It requires no separate signal conditioning.

Our LIPS[®] range are linear sensors, while RIPS[®] are rotary units and TIPS[®] are for detecting tilt position. Ask us for a full technical explanation of PIPS[®] technology.

We also offer a range of ATEX-qualified intrinsically-safe sensors.

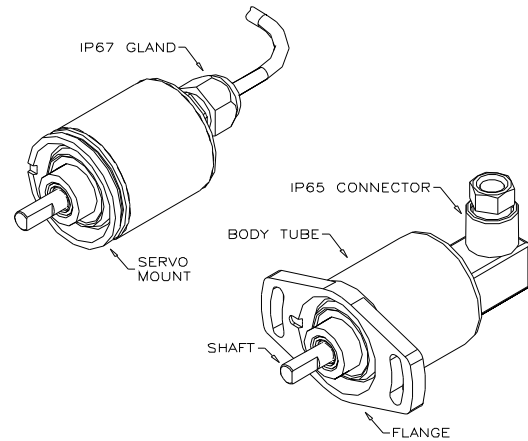

TABLE OF OPTIONS

MEASUREMENT RANGE: Factory-set to any angle from $\pm 10^\circ$ to $\pm 80^\circ$ in increments of 1 degree.
 Full 360° Mechanical rotation.

ELECTRICAL INTERFACE OPTIONS

OUTPUT SIGNAL	SUPPLY INPUT	OUTPUT LOAD
Standard:		
0.5-4.5V dc ratiometric	+5V dc nom. $\pm 0.5V$.	2k Ω min.
Buffered:		
0.5-4.5V dc	+24V dc nom. + 9-28V.	2k Ω min.
$\pm 5V$ dc	$\pm 15V$ dc nom. $\pm 9-28V$.	2k Ω min.
0.5-9.5V dc	+24V dc nom. + 13-28V.	5k Ω min.
$\pm 10V$ dc	$\pm 15V$ dc nom. $\pm 13.5-28V$.	5k Ω min.
Supply Current	10mA typical, 20mA maximum.	
4-20mA (2 wire)	+24 V dc nom. + 18-28V.	300 Ω @ 24V.
(3 wire sink)	+24 V dc nom. + 13-28V.	950 Ω @ 24V.
(3 wire source)	+24 V dc nom. + 13-28V.	300 Ω max.

Option for output 'zero' and 'span' adjustment available.

CONNECTOR/CABLE OPTIONS

Connector - Hirschmann GD series IP65
 Cable with M12 gland or short gland IP67
 Cable length >50cm – please specify length in cm

MOUNTING OPTIONS

Flange 2 off 4.5 mm x 30 degree wide slots, 48 mm PCD.
 Servo 2 mm wide groove, internal diameter 31.8 mm.

