

# RIPS<sup>®</sup> P503 FLAT ROTARY SENSOR ASSEMBLY

High-resolution angle feedback for industrial and scientific applications

- Non-contacting inductive technology to eliminate wear
- Angle set to customer's requirement
- Compact PCB design, durable and reliable
- High accuracy and stability

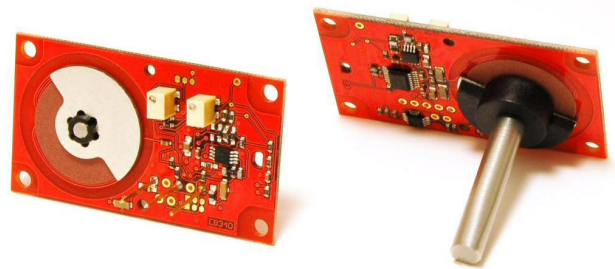

As a leading designer and manufacturer of linear, rotary, tilt and intrinsically safe position sensors, Positek<sup>®</sup> has the expertise to supply a sensor to suit a wide variety of applications.

The P503 RIPS<sup>®</sup> (Rotary Inductive Position Sensor) is a low-cost assembly designed particularly for OEM users.

Like all Positek<sup>®</sup> sensors it provides a linear output proportional with angle of rotation. Each unit is supplied with the output calibrated to the angle required by the customer, between 20 and 160 degrees.

With suitable mounting and bearings, overall performance, repeatability and stability are outstanding over a wide temperature range.

This very compact sensor, supplied as a printed circuit board sub-assembly, has a range of electrical options.

The P503 is ready to mount directly in customer's equipment. Connections to the sensor are made via solder pins.

## SPECIFICATION

### DIMENSIONS

Board Outline	56 x 32 x 6 mm standard
Board Outline	56 x 32 x 12.5 mm buffered
Shaft	31 mm Ø 6mm

*For full mechanical details see drawing P503-11*

Independent linearity	< ± 0.5% FSO up to 100° travel @ 20°C
Temperature coefficients	< ± 0.01%/°C Gain &

	< ± 0.01%FS/°C Offset
Frequency response	> 10 kHz (-3dB)
	> 300 Hz (-3dB) 2 wire 4 to 20 mA

### Resolution

Infinite

### Noise

< 0.02% FSO

### Torque

<20 mNm Static

### Environmental Temperature Limits

Operating

-40 to +125°C standard

-20 to +85°C buffered

-40 to +125°C

Storage

Unsealed

Sealing

IEC 68-2-6: 10g

Vibration

IEC 68-2-29: 40 g

Shock

350,000 hrs 40°C Gf

MTBF

Drawing List

P503-11

Outline

Drawings, in AutoCAD<sup>®</sup> dwg or dxf format, available on request.

Do you need a position sensor made to order to suit a particular installation requirement or specification? We'll be happy to modify any of our designs to suit your needs - please contact us with your requirements.

# RIPS<sup>®</sup> P503 FLAT ROTARY SENSOR ASSEMBLY

High-resolution angle feedback for industrial and scientific applications

## How Positek's PIPS<sup>®</sup> technology eliminates wear for longer life

Positek's PIPS<sup>®</sup> technology (Positek Inductive Position Sensor) is a major advance in displacement sensor design. PIPS<sup>®</sup>-based displacement transducers have the simplicity of a potentiometer with the life of an LVDT/RVDT.

PIPS<sup>®</sup> technology combines the best in fundamental inductive principles with advanced micro-electronic integrated circuit technology. A PIPS<sup>®</sup> sensor, based on simple inductive coils using Positek's ASIC control technology, directly measures absolute position giving a DC analogue output signal. Because there is no contact between moving electrical components, reliability is high and wear is eliminated for an exceptionally long life.

PIPS<sup>®</sup> overcomes the drawbacks of LVDT technology – bulky coils, poor length-to-stroke ratio and the need for special magnetic materials. It requires no separate signal conditioning.

Our LIPS<sup>®</sup> range are linear sensors, while RIPS<sup>®</sup> are rotary units and TIPS<sup>®</sup> are for detecting tilt position. Ask us for a full technical explanation of PIPS<sup>®</sup> technology.

We also offer a range of ATEX-qualified intrinsically-safe sensors.

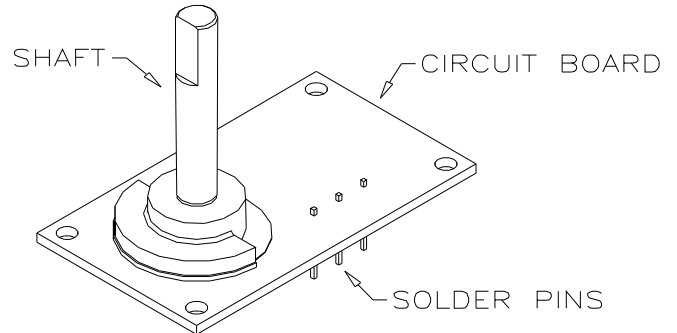

### TABLE OF OPTIONS

**MEASUREMENT RANGE:** Factory-set to any angle from  $\pm 10^\circ$  to  $\pm 80^\circ$  in increments of 1 degree.  
 Full 360° Mechanical rotation.

#### ELECTRICAL INTERFACE OPTIONS

OUTPUT SIGNAL	SUPPLY INPUT	OUTPUT LOAD
Standard:		
0.5-4.5V dc ratiometric	+5V dc nom. $\pm 0.5V$ .	2k $\Omega$ min.
Buffered:		
0.5-4.5V dc	+24V dc nom. + 9-28V.	2k $\Omega$ min.
$\pm 5V$ dc	$\pm 15V$ dc nom. $\pm 9-28V$ .	2k $\Omega$ min.
0.5-9.5V dc	+24V dc nom. + 13-28V.	5k $\Omega$ min.
$\pm 10V$ dc	$\pm 15V$ dc nom. $\pm 13.5-28V$ .	5k $\Omega$ min.
Supply Current	10mA typical, 20mA maximum.	
4-20mA (2 wire)	+24 V dc nom. + 18-28V.	300 $\Omega$ @ 24V.
(3 wire sink)	+24 V dc nom. + 13-28V.	950 $\Omega$ @ 24V.
(3 wire source)	+24 V dc nom. + 13-28V.	300 $\Omega$ max.

Output 'zero' and 'span' adjustment available.

