

# TIPS<sup>®</sup> X603 LARGE ANGLE TILT SENSOR

## INTRINSICALLY SAFE FOR HAZARDOUS GAS/VAPOUR ATMOSPHERES

- Intrinsically safe for Gas to:  
Ex II 1G
- Non-contacting inductive technology to eliminate wear
- Angle set to customer's requirement
- Compact and self-contained
- High durability and reliability
- Sealing to IP67



As a leading designer and manufacturer of linear, rotary, tilt and intrinsically safe position sensors, Positek<sup>®</sup> has the expertise to supply a sensor to suit a wide variety of applications.

Our X603 TIPS<sup>®</sup> (Tilt Inductive Position Sensor) incorporates electronics system EX04 which is ATEX approved for use in potentially explosive gas/vapour atmospheres. The X603 is designed for industrial and scientific feedback applications and is ideal for OEMs seeking good sensor performance for arduous applications in hazardous areas. The X603, like all Positek<sup>®</sup> sensors, is supplied with the output calibrated to the angle required by the customer, between 20 and 160 degrees and with full EMC protection built in. The sensor provides a linear output characteristic with angle of deflection. There is a machined registration mark to identify the calibrated mid point.

Overall performance, repeatability and stability are outstanding over a wide temperature range. Electrical connections to the sensor are made via an industrial standard 4-pin M12 connector, with limited rotational capability to facilitate cable routing.

The sensor has a rugged stainless steel body. The flange has two 4.5mm by 30 degree wide slots on a 48mm pitch to simplify mounting and position adjustment. Environmental sealing is to IP67.

### SPECIFICATION

#### DIMENSIONS

Body diameter	35 mm
Body Length (to seal face)	44 mm

*For full mechanical details see drawing X603-11*

Power Supply	+5V dc nom. $\pm$ 0.5V, 10mA typ 20mA max
Output Signal	0.5-4.5V dc ratiometric, Load: 2k $\Omega$ min.

#### Independent linearity/Hysteresis

(combined error)	< $\pm$ 0.25 degrees
Temperature coefficients	< $\pm$ 0.01%/°C Gain & < $\pm$ 0.01%FS/°C Offset

Response time 250 mS @ 20°C typ.

Resolution Infinite

Damping ratio 0.2 : 1 (0.6 nom. @ 25°C)

Noise < 0.02% FSO

Intrinsic Safety Ex II 1G

EEEx ia IIC T4 (Ta = -40°C to +80°C)

Sensor Input parameters Ui: 11.4V, Ii: 0.20A, Pi: 0.51W.

Ci: 1.16 $\mu$ F, Li: 50 $\mu$ H

#### Environmental Temperature Limits

Operating	-20 to +80°C
Storage	-40 to +125°C

Sealing IP67

EMC Performance EN 61000-6-2, EN 61000-6-3

Vibration IEC 68-2-6: 10g

Shock IEC 68-2-29: 40 g

MTBF 350,000 hrs 40°C Gf

Drawing List

X603-11 Sensor Outline

*Drawings, in AutoCAD<sup>®</sup> dwg or dxf format, available on request.*

Do you need a position sensor made to order to suit a particular installation requirement or specification? We'll be happy to modify any of our designs to suit your needs - please contact us with your requirements.

# TIPS<sup>®</sup> X603 LARGE ANGLE TILT SENSOR

## INTRINSICALLY SAFE FOR HAZARDOUS GAS/VAPOUR ATMOSPHERES

Intrinsically safe equipment is defined as "equipment which is incapable of releasing sufficient electrical or thermal energy under normal or abnormal conditions to cause ignition of a specific hazardous atmosphere mixture in its most easily ignited concentration."

ATEX approved to; Ex II 1G  
 EEx ia IIC T4 (Ta = -40°C to +80°C)

Designates the sensor as belonging to; Group II: suitable for all areas **except mining**, Category 1 G: can be used in areas with continuous, long or frequent periods of exposure to hazardous gas (Zone 0).

Protection class ia, denotes intrinsically safe for all zones

Apparatus group IIC: suitable for IIA to IIC explosive gas.

Temperature class T4: maximum surface temperature under fault conditions 135°C.

Ambient temperature range extended to -40°C to +80°C.

It is imperative Positek<sup>®</sup> intrinsically safe sensors be used in conjunction with a galvanic barrier to meet the requirements of the product certification. The Positek X005 Galvanic Isolation Amplifier is purpose made for Positek IS sensors making it the perfect choice. Refer to the X005 datasheet for product specification and output configuration options.

### Safety Parameters:-

Ui: 11.4V, Ii: 0.20A, Pi: 0.51W

Ci = 1.16µF Li = 50µH

Sensors can be installed with a maximum of 1000m of cable.

Cable characteristics must not exceed:-

Capacitance: ≤ 200 pF/m for max. total of: 200 nF.

Inductance: ≤ 660 nH/m for max. total of: 660 µH

For cable lengths exceeding 10 metres a five wire connection is recommended to eliminate errors introduced by cable resistance and associated temperature coefficients.

ATEX approved sensors suitable for dust (E series) and mining (M series) applications, are also available from Positek.

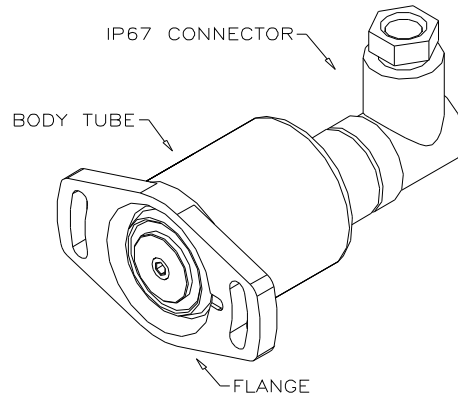

### TABLE OF OPTIONS

**MEASUREMENT RANGE:** Factory-set to any angle from ±10° to ±80° in increments of 1 degree.  
 Full 360° Mechanical rotation.

### ELECTRICAL INTERFACE OPTIONS

The Positek<sup>®</sup> X005 Galvanic Isolation Amplifier is available with 0.5-9.5V or 4-20mA transmission output options.

### CONNECTOR

Connector - Binder 713 series IP67

We recommend all customers refer to the 3 or 5-Wire Mode Connection page

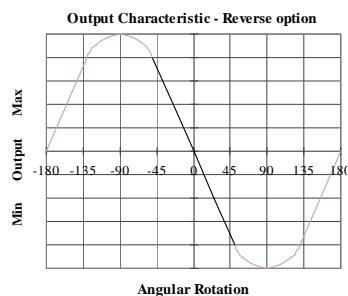
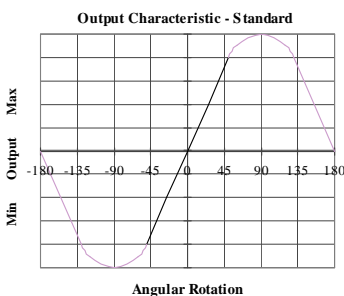

# Three or Five-Wire Mode Connection

## FOR INTRINSICALLY SAFE SENSORS IN HAZARDOUS ATMOSPHERES

The following discussion about three and five wire mode connections, between the X005 Galvanic Isolation Amplifier and sensor, is intended as an aid for end-users who are not familiar with the topic.

Whether opting for a pre-wired Positek® Intrinsically Safe sensor or one with a connector, choosing the right mode of connection and cable to suit the application requires careful consideration.

Conductor resistance, a function of conductor cross-section, cable length and temperature, causes volts drop across a cable. As the term implies cables do not transmit the voltage perfectly, depending on material resistivity, conductor cross section and the current drawn from the power supply the voltage at the end of the cable will be less than at the power supply. This can significantly alter the perceived accuracy of the sensor which is ratiometric i.e. the output signal is directly affected by the supply voltage at the sensor.

It should be noted that volts drop calculations consider the current flow return path so the cable length is multiplied by two.

Three wire mode connections are common and are suitable in most cases with short or moderate cable runs. Applications that do not require a high degree of accuracy but have cable runs, say in excess of 50m, volts drop can be reduced by introducing a terminal box close to the sensor and using a larger cross-section cable with for a majority of the intended cable run. Another factor to consider is conductor temperature. Fluctuations in temperature cause minor changes in resistance, the effects of which will be seen as gain variation in the sensor output.

Sensors supplied with cable are calibrated with the cable fitted which negates errors due to conductor resistance at room temperature; however, small gain errors due to temperature fluctuations in the cable should be expected.

There are instances where large cross-section cables are not practical; for example most standard industrial connectors of the type used for sensors have a maximum conductor capacity of 0.75mm<sup>2</sup>, copper prices and ease of installation are other considerations.

Five wire mode connections have significant benefits over three wire mode as losses in the power and ground conductors are compensated for, thus smaller cables can be used. The Galvanic Isolation Amplifier senses and dynamically adjusts the output voltage so that the voltage at the sensor is correct, the effects of cable resistance and associated temperature coefficients are eliminated. The X005 amplifier can compensate for up to 15Ω per conductor with a current flow of 15mA, which is more than adequate for 150m of 0.25mm<sup>2</sup> cable.

For this reason Positek recommends five wire connections for cable lengths exceeding 10 metres in 0.25 mm<sup>2</sup> cable to preserve the full accuracy of the sensor.

See illustrations right for examples of connecting a sensor to the Galvanic Isolation Amplifier.

The X005 will compensate for up to 15 ohms resistance in each conductor, this imposes the following minimum cable sizes: -

Cross Section (mm <sup>2</sup> )	Cable Length (metres)
0.25	Up to 150
0.5	150 to 300
0.75	300 to 450
1.0	450 to 600
1.5	600 to 900
2.0	900 to 1000

It should be noted that the maximum cable length as specified in the sensors certification takes precedence and must not be exceeded.

The above lengths and conductor sizes used in a three wire connection will introduce a gain reduction of 5% and a ±1% temperature dependence of gain over the range -40°C to +80°C for the cable temperature. (i.e. about -150 ppm/°C for the maximum lengths shown and less pro rata for shorter lengths.)

