

# Installation Information

## RIPS<sup>®</sup> P505 SLIM-LINE ROTARY SENSOR

Output Option	Output Description:	Supply Voltage: V <sub>s</sub> (tolerance)	Load resistance: (include leads for 4 to 20mA O/Ps)
<b>A</b>	0.5 - 4.5V (ratiometric with supply)	+5V (4.5 - 5.5V)	≥ 5kΩ
<b>C</b>	0.5 - 9.5V	+24V nom. (13 - 28V)	≥ 5kΩ
<b>G</b>	0.5 - 4.5V	+24V nom. (9 - 28V)	≥ 5kΩ

Not all output options available - see product datasheet for full options list

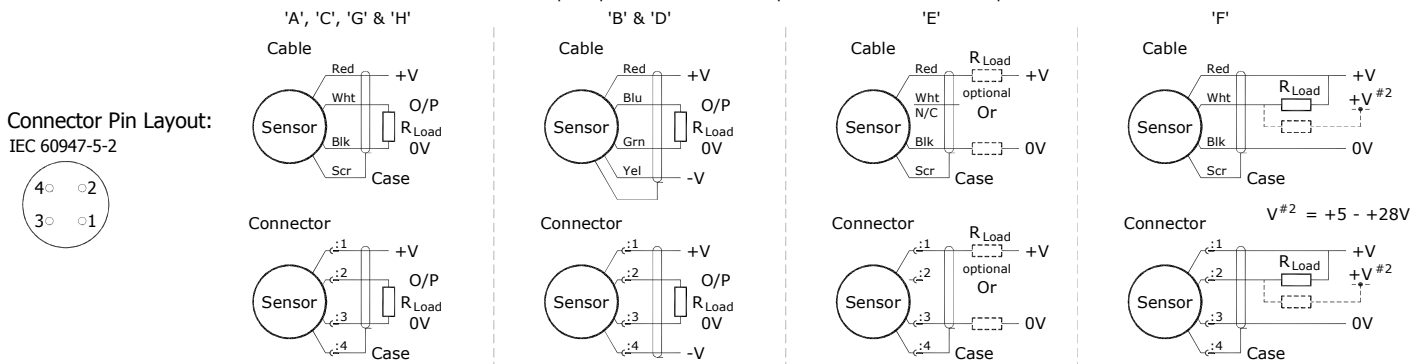

**Mechanical Mounting:** Flange mounted. The flange slots are 3.2mm by 30 degrees wide on a 25mm pitch. The sensor should be mounted with minimal axial and radial loading on the shaft for optimum life. It is recommended that the shaft is coupled to the drive using a flexible coupling.

**Output Characteristic:** The sensor has full rotational freedom and two sectors, 180° apart, over which linear response can be achieved. At the mid point of the calibrated range the output signal will be half full scale deflection, and the flat on the shaft is aligned with the registration mark in the base of the sensor. In the calibrated range the output increases as the shaft is rotated in an anti-clockwise direction viewed from the shaft. The calibrated output is factory set to be between 15 and 160°.

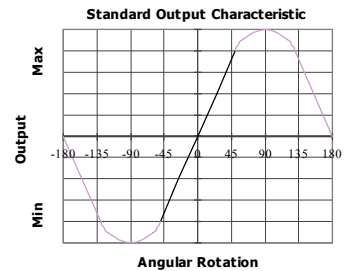

**Incorrect Connection Protection levels:-**

- A **Not protected** – the sensor is **not** protected against either reverse polarity or over-voltage. The risk of damage should be minimal where the supply current is limited to less than 50mA.
- C & G Supply leads diode protected. Output must not be taken outside 0 to 12V.